

REVERSING DRUM MIXER

Stephens
Workhorse 

Stephens
Workhorse 



Stephens 
CONCRETE PLANTS • Tompkinsville, KY

800-626-0200
www.stephensmfg.com

A New Spin on Mixers

It is only sand, rock, water, and cement until you mix it

Without proper mixing, concrete will fail to achieve its desired properties. Good mixing is critical in promoting hydration, allowing development of the desired cement paste. Mixing promotes proper dispersion of the sand and aggregates within the cement paste, ensuring that the concrete develops the intended workability and strength.

Mixing is at the heart of the concrete production process

The mixer is the heart of any central mix plant. The mixer governs the quality and productivity of the concrete plant and directly affects the profitability of the operation. Tilting, Twin Shaft, Planetary, Pan and Reversing drum are common concrete mixing technologies. All these mixing technologies can produce quality concrete, but each technology has unique advantages and drawbacks. How do you know which technology is right for you?

Why choose reversing drum mixing?

Leading-edge reversing drum technology can surpass the mixing performance of the other systems, while eliminating many of the drawbacks. With reversing drum systems, drum rotation in one direction mixes the contents while rotation in the opposite direction discharges the drum. Paddles and rakes mounted inside the drum create high shear conditions during drum rotation. This simple mixing principle minimizes the number of moving parts compared to other mixers, resulting in an efficient, reliable, and low cost mixing solution.

Stephens Workhorse reversing drum mixers lead the pack

The elegantly simple design of the reversing drum mixer reflects three decades of research spent developing and refining. This was the first reversing drum mixer introduced in North America. The mixer is now owned, marketed and manufactured by Stephens Mfg. as the Workhorse Mixer. Our commitment to industry leading technology, quality, and customer service has made us the right choice.

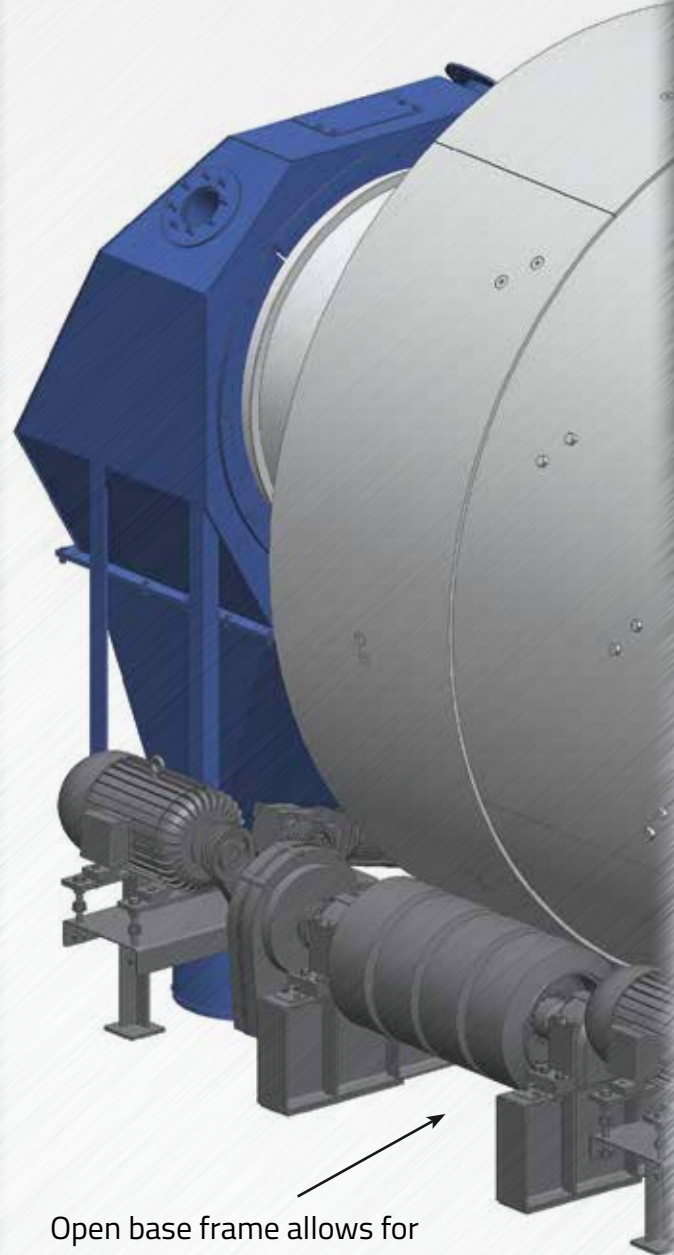

Open base frame allows for easy cleaning under mixer

A safety fence is standard with each Workhorse mixer, to guard moving parts and pinch points.

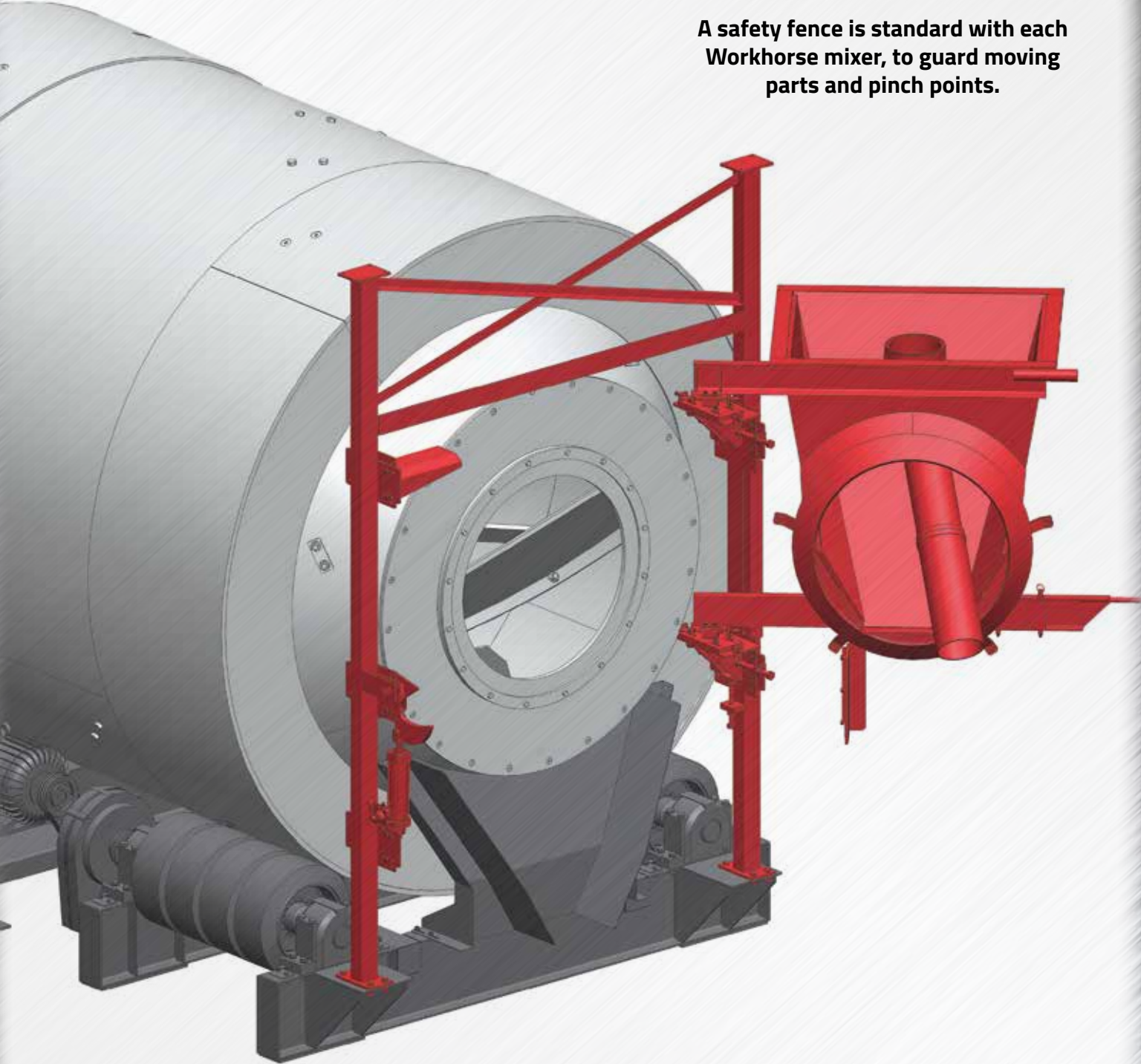

Reversing drum mixer operating principle

A charge chute directs materials into the mixing drum. The positive seal between the chute and drum prevents dust escaping from the mixer.

While loading, electric motors coupled with urethane drive wheels rotate the drum. Drum rotation causes the drum contents to pass over and through an array of wear resistant paddles while longitudinal rakes promote lateral motion of drum contents,

creating an efficient and forceful three-dimensional mixing action inside the drum.

After mixing is complete, the drum rotates in the opposite direction, allowing proprietary discharge shovels to empty the drum's contents into the discharge chute. Specially designed discharge cones ensure smooth, pulse, and splatter free concrete flow into the downstream process.

charging sequence

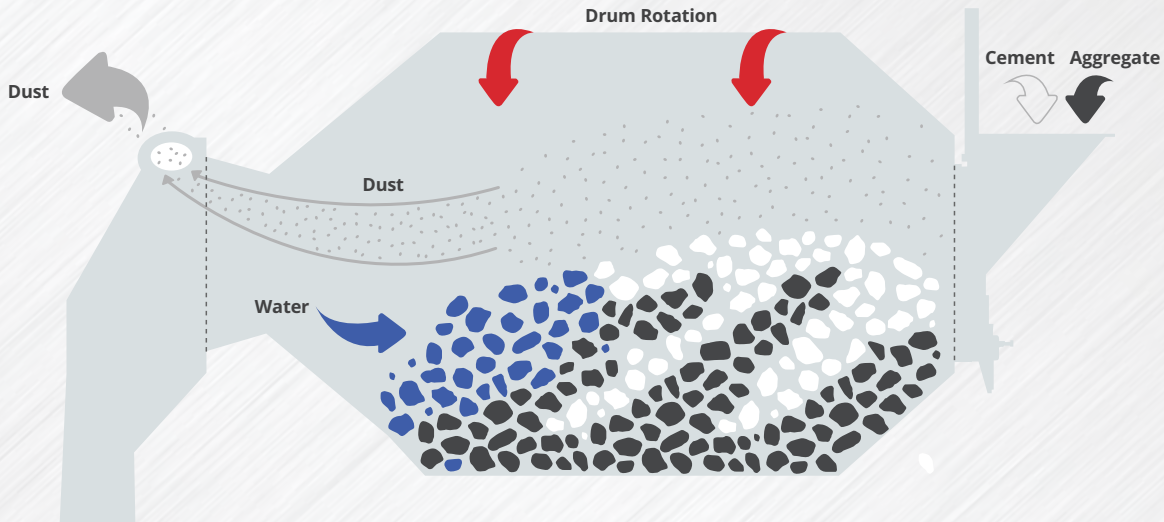

discharge sequence

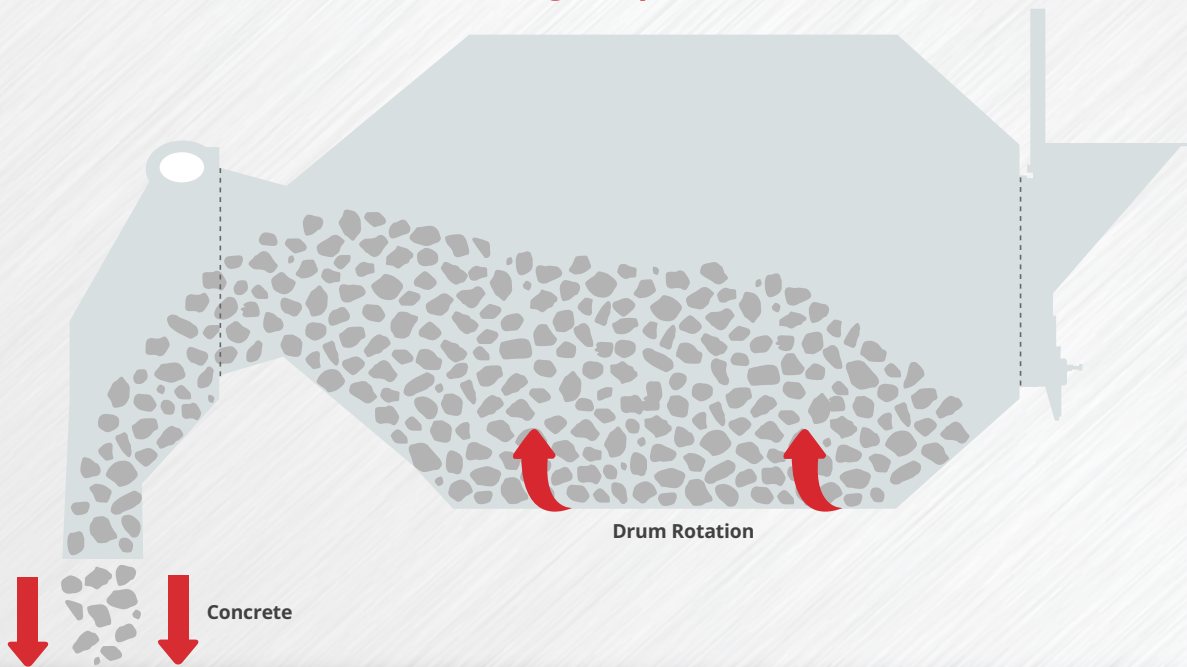

Benefits of the reversing drum mixer



fast, clean mixing

- The fully enclosed charge and discharge points control dust and minimize splatter. The optimized mixing paddle and rake configuration promote rapid homogenization of the drum contents.
- Reversed drum rotation causes the paddles to discharge a smooth stream of concrete from the mixer, allowing fast delivery of the concrete to the trucks or downstream process.
- The reversing action also promotes cleaning the back side of racks and paddles.



energy efficient mixing

- Proprietary paddle and rake features create high shear action in the mixer drum at low rotational speeds, resulting in less energy consumption during moving.
- The paddles and rakes promote both radial and lateral mixing of the drum contents to achieve fast, thorough mixing.
- Variable frequency drives control the drum motors, reducing in rush current, peak power demand and reducing the cost of peak charges imposed by utility companies.



quiet operation

- Many features of the mixer combine to create a quiet mixing process. The reversing drum system does away with the noisy ring gear drive and hydraulic motors used by other systems for tilting or discharge.
- The drum is mounted and driven with urethane drive wheels, eliminating metal-on-metal noise while the urethane wheels absorb the vibration from drum rotation and material charging processes.
- The sealed inlet and outlet ports provide sound baffling, further reducing mixer noise, resulting in one of the quietest mixing processes on the market.



lower maintenance costs

- The design of the Stephens Workhorse reversing drum mixer has significantly fewer moving parts than other mixing systems, meaning fewer things to go wrong.
- Replaceable, wear resistant liners and paddles extend mixer life, allowing easy replacement of worn components.
- A hinged charge chute and removable mixer-drum sections provide unrestricted access inside the drum, improving maintainability.
- The mixer employs proven, off-the-shelf bearings, gearboxes, and motors to improve serviceability, reliability, and availability of replacement parts.

Standard Mixer Features

Drive System Features

The Stephens Workhorse mixer employs proven drive technology to ensure operational reliability, energy efficiency, and durability.

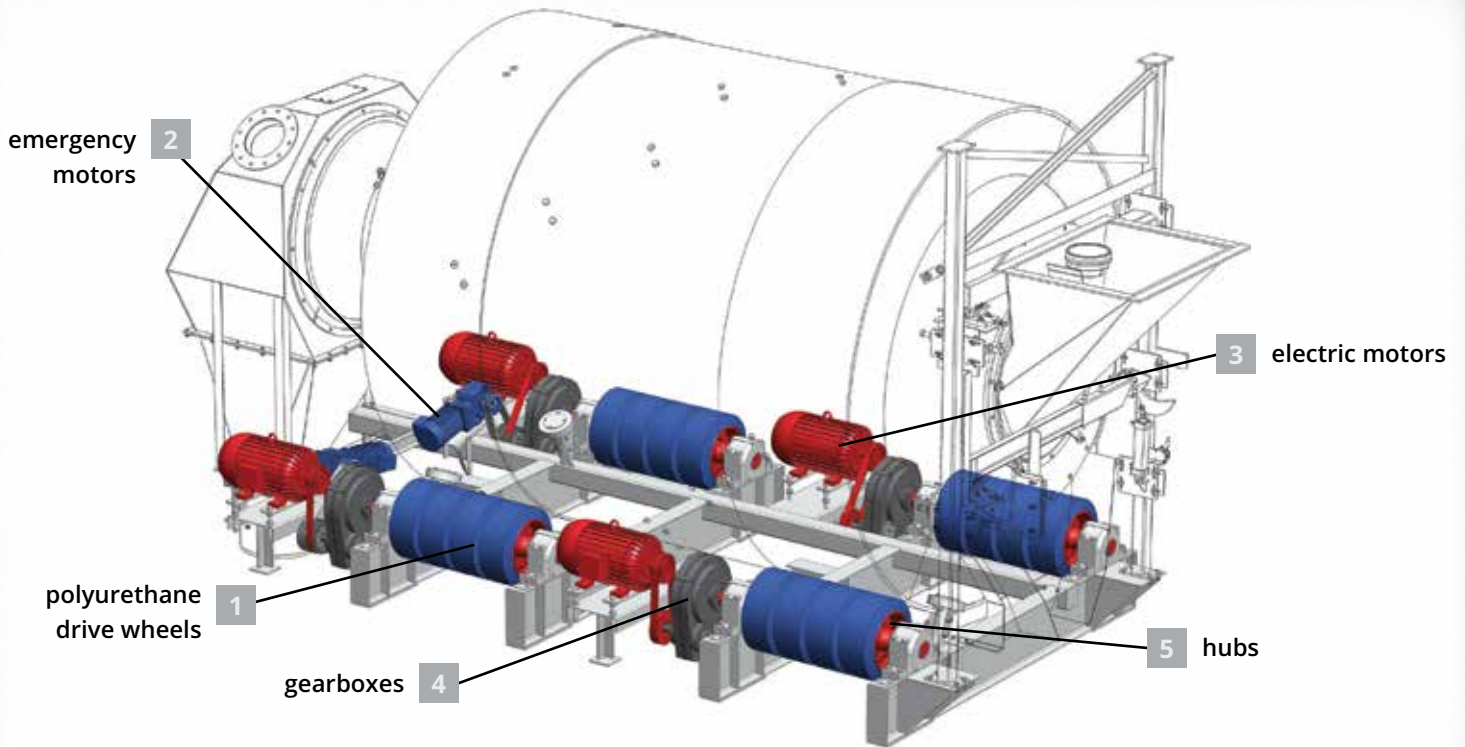

1 Polyurethane Drive Wheels

The mixer drum mounts on urethane drive wheels, eliminating metal on metal wear and reducing noise and vibration caused by the mixing process. Replacement of competitor's ring gear is a major shutdown both in lost production, to do the work, and costly to buy and warehouse.

2 Electric Motors

The drive motors are high efficiency, totally enclosed, fan cooled units well suited for this heavy-duty application. Motor specifications ensure enough torque and horsepower is available to handle all scenarios.

3 Emergency Motors

3 phase auxiliary electric motors can discharge the mixer contents in the event of power failure. Generator by customer or optional.

4 Gearboxes

The oversized gearbox can withstand the largest drum loads. The gearbox connects to motor and hub drive shafts allowing for easy servicing.

5 Hubs

A simple, robust wheel hub design can easily withstand forces from the motors and the mixer drum, making service and adjustment of tires simple.

6 VFD Control System

Motor control allows adjustment of mixing speed for both directions. Regulation of discharge speeds allows optimal rates of concrete transfer from the drum. When holding mixed materials in the drum, a low speed (idle) feature slows drum rotation, keeping the concrete mixed while slowing the hydration process.

7 Maintenance Control Panel

A panel mounted near the mixer gives maintenance workers control over drum rotation, allowing them to rotate the drum as needed to facilitate maintenance.

Drum and Mixing Tools

Innovative mixing features inside the drum promote thorough rapid concrete mixing, while discharge features achieve rapid emptying of mixed concrete from the drum.

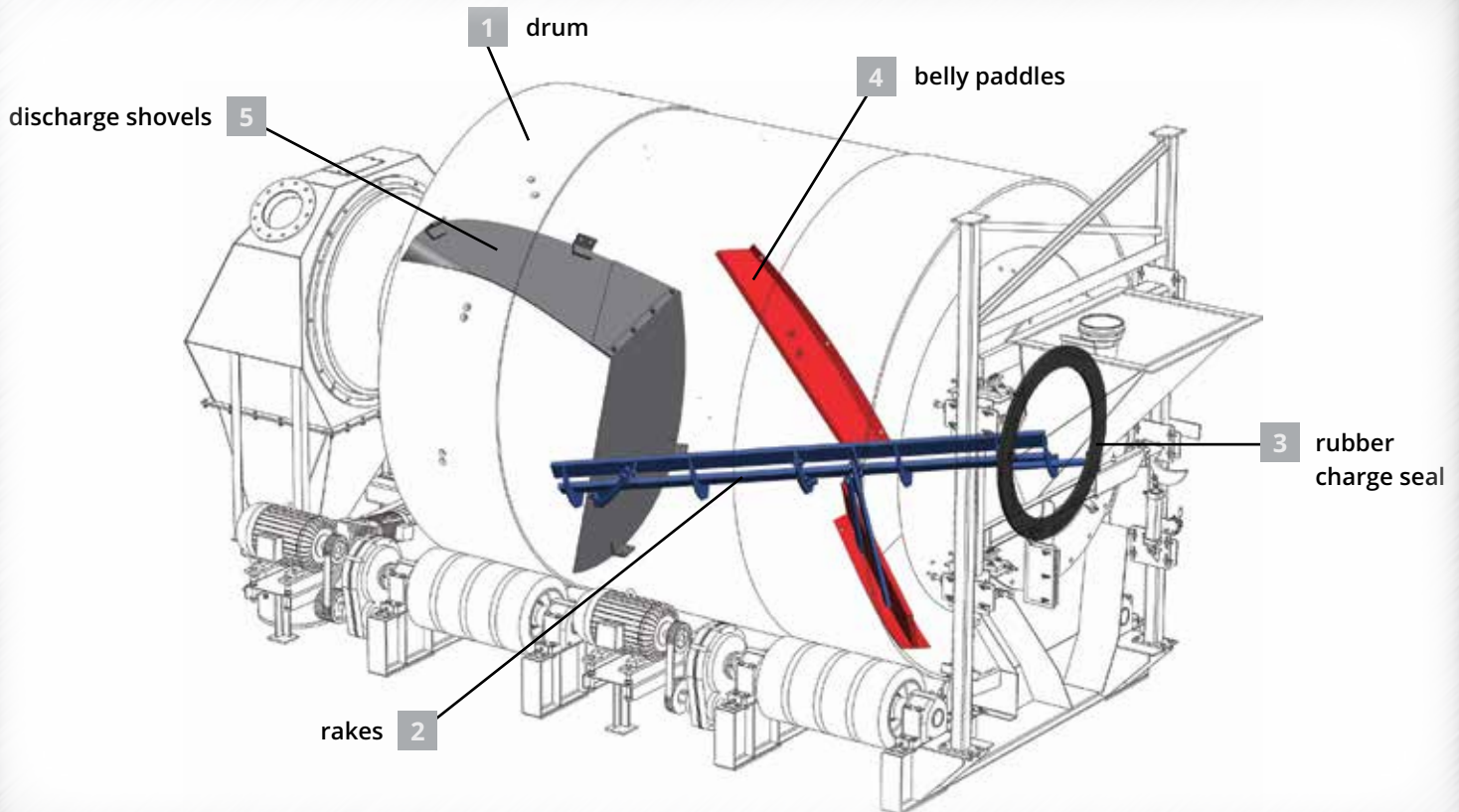

1 Drum

Drum construction features 3/8" plate steel, with 1" plate on drive lanes. 1" thick polyurethane liner inside drum reduces drum wear. The non-stick properties of the wear liner improves drum cleaning.

2 Rakes

Internal rakes, spanning the length of the drum, move concrete end-to-end inside the drum, promoting three-dimensional material mixing. The rakes are lined with 1" thick polyurethane.

3 Rubber Charge Seal

The Rubber seal provides a flexible joint between the charge chute and the drum. The seal minimizes spillage and facilitates dust capture.

4 Belly Paddles

Mounted on the inside drum surface is a series of 1/2" steel paddles with 3/8" bases and 1" polyurethane liner covering wear prone surfaces. The paddle design and orientation within the drum creates high shear mixing of the concrete.

5 Discharge Shovels

Designed to force concrete from the drum, the shovels promote rapid, uniform discharge of drum contents. Innovative shovel designs are compatible with a range of concrete types. Shovels are lined with 3/8" 400 Brinnell A/R liners.

Swinging Charge Chute PATENTED

The charge chute mounts on a hinged joint, allowing it to pivot away from the mixer to give easy maintenance access to the inside of the drum.

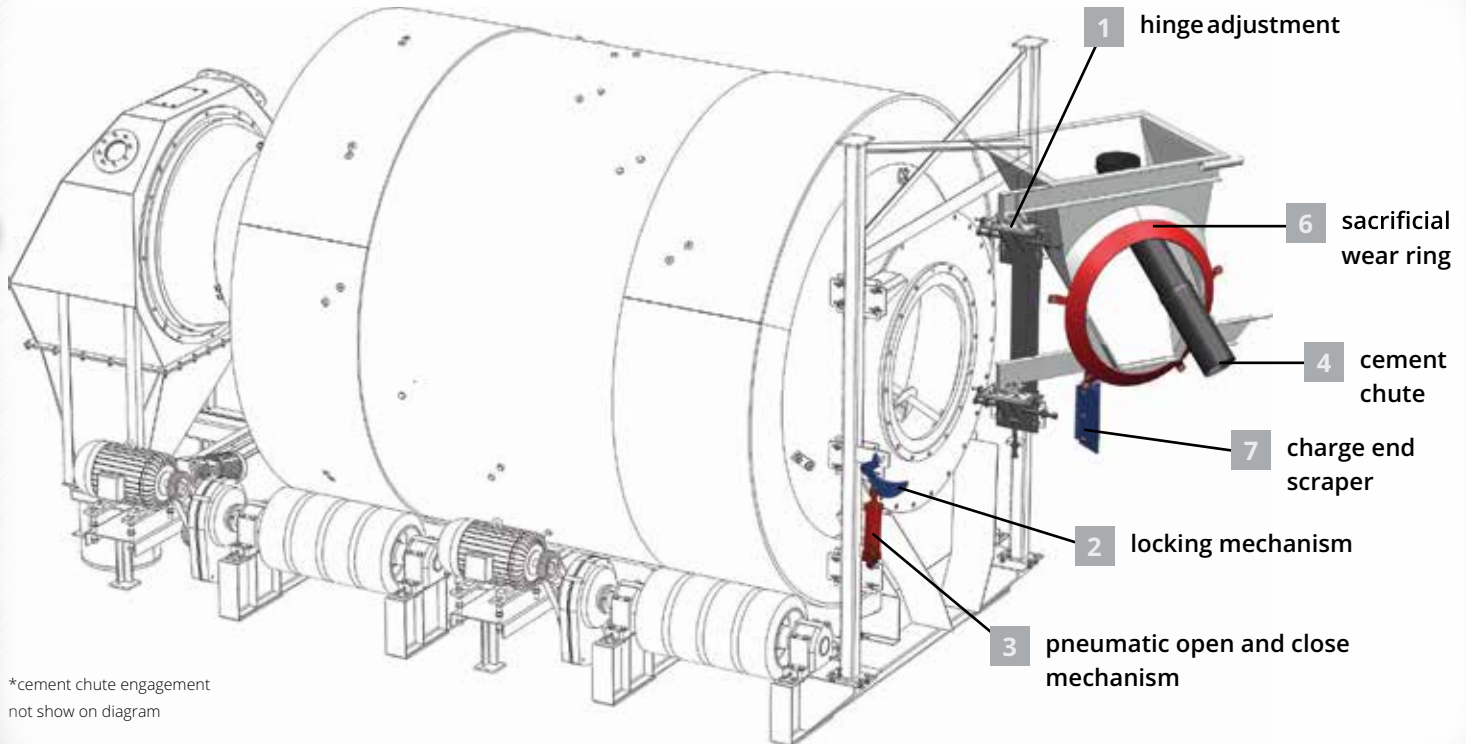

*cement chute engagement not show on diagram

1 Fine and Coarse Hinge Adjustment

Adjustment plates allow precise special adjustments to the charge chute position, allowing proper seal between drum and charge chute. Ability to reposition the chute compensates for charge seal wear, maintaining the positive seal.

2 Locking Mechanism

Mechanism ensures the charge chute remains fixed in position and prevents unintentional chute opening.

3 Pneumatic Open and Close Mechanism

A cylinder affects opening and closing of the charge chute and ensures proper sealing between the chute, seal, and drum.

4 Cement Chute

A dedicated rigid pipe inside the charge chute delivers cement into the mixer. The chute helps keep the cement dry prior to entering the mixer, aids in minimizing process dust, and creates a better charging sequence.

5 Cement Chute Engagement (Optional)

A simple compression fit coupling prevents cement leakage while allowing easy manual disengagement of the cement chute to decouple it from the charge chute (not shown).

6 Sacrificial Wear Ring

A ring feature at the end of the mix drum accepts the frictional wear caused by drum rotation. The simple bolt-on configuration allows easy replacement of worn rings.

7 Charge End Scraper

A urethane blade coupled to the mixer frame provides continuous cleaning of the charge side of the mixer, reducing clean up at the end of the day.

8 Charging Chute

Charging chute wear surfaces are lined with 1" thick polyurethane.

Discharge Chute

The discharge chute and related components promote clean transfer of the mixed concrete to the downstream process while helping to control dust and minimize noise.

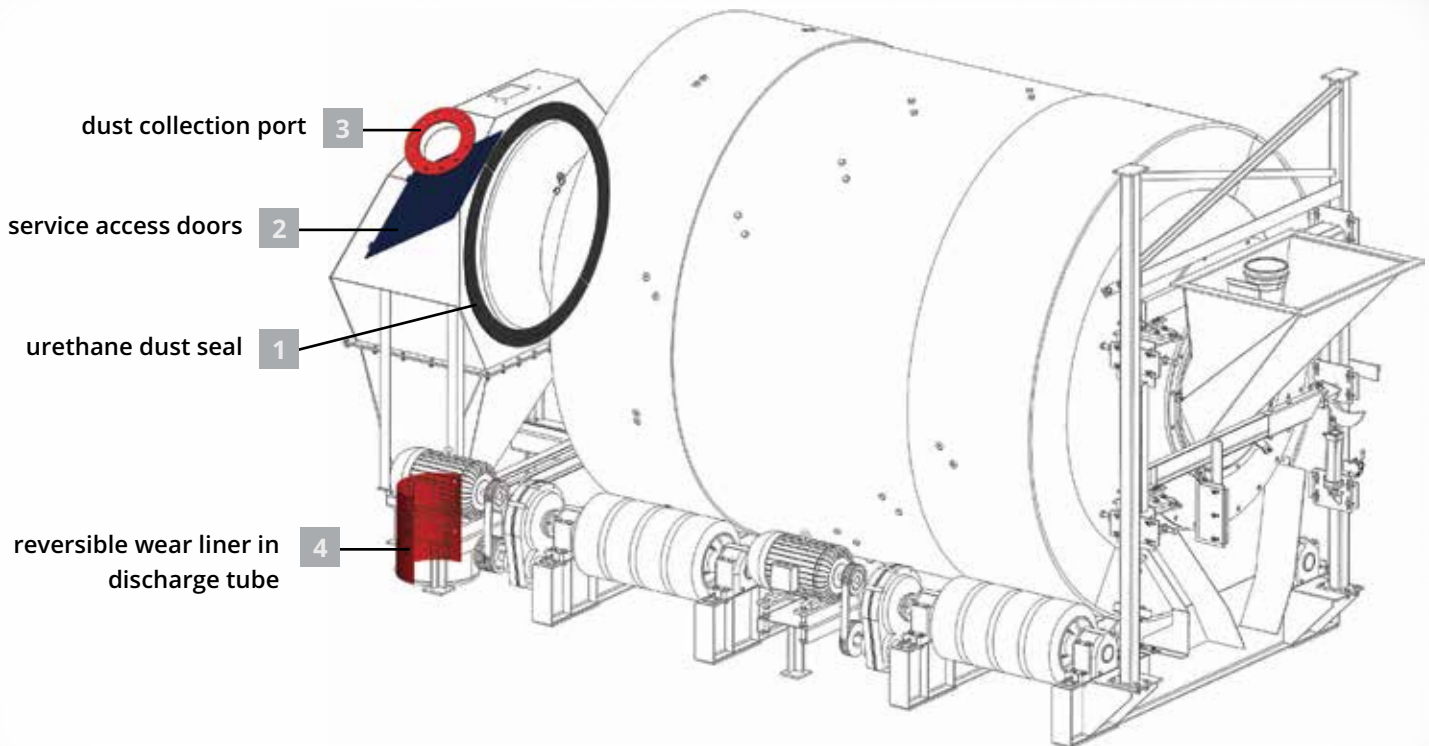

1 Urethane Dust Seal

The seal mates the discharge chute to the rotating drum, capturing dust and controlling spillage.

2 Service Access Doors

A wide double door provides clear access inside the discharge chute and into the discharge side of the mixer.

3 Dust Collection Port

An integrated 012" flanged connection point provides an optimal method for coupling dust systems to the mixer.

4 Reversible Wear Liner in Discharge Tube

The discharge tube has a 4-way reversible wear liner, maximizing wear plate life before replacement.

5 Discharge Chute

The discharge chute wear surface is lined with 1" thick polyurethane liner.

Optional Mixer Features +

In addition to the standard features, Stephens offers a number of optional features to tailor the mixer to your specific requirements.



High Shear Belly Paddles PATENT PENDING

An alternate belly paddle design incorporates additional *shear promoting* features to achieve improved mixing. The high shear paddles are suitable for use with certain mixers where slump is 6" or higher.

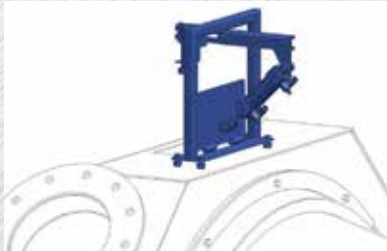

Camera/Temperature Probe Hatch

A hatch port provides cameras and non-invasive temperature probes access to inside the mixer discharge. Streaming data back to the batch computer allows automatic batch-to-batch recipe adjustment. Camera ports include an air curtain to protect the camera lens from dust.

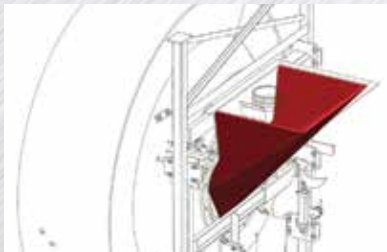

High Durability Charge Chute Liners

Polyurethane liners with embedded ceramic tiles or Chrome Carbide liners are available to provide improved abrasion resistance. These liners are well suited for use with abrasive aggregates or in high volume applications.

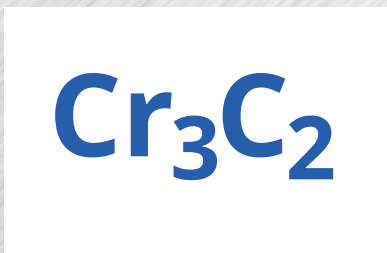

Chromium Carbide Paddle and Rake Liners

The hardness of these liners provides additional wear resistance compared to our standard polyurethane liners.

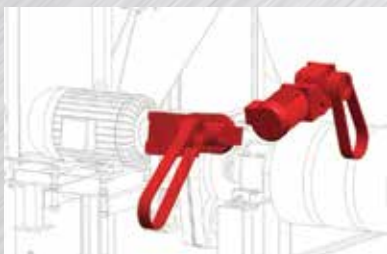

Hydraulic Emergency Drive

In the event of a power loss, a hydraulic back-up drive system can discharge the drum contents, preventing the concrete from setting in the mixing drum. Systems can also be provided to use a loader or mixer truck to provide the hydraulic pressure required to power the drive.



Mixer Moisture Meter

A moisture probe embedded in the drum provides continuous monitoring of the moisture content.

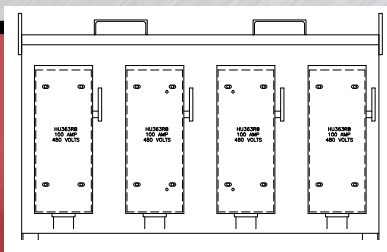

Individual Disconnects

individual disconnects are recommended on each 50hp motor.

Specifications

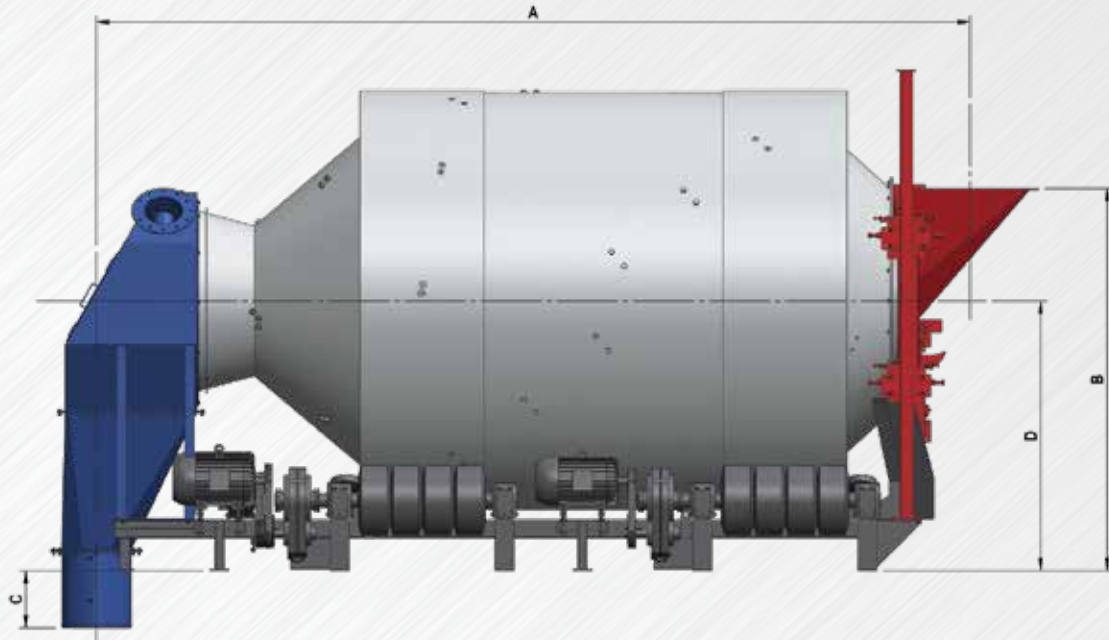

CAPACITY	DRUM DIAMETER	DRIVE MOTORS	OVERALL DIMENSIONS				WEIGHT
			A	B	C	D	
m ³	mm	kW	mm				kg
y ³	in	hp	in				lbs
3	2500	2 x 22	4500	2400	400	1700	12000
4	99	2 x 30	177	96	16	66	26000
4.5	2800	4 x 18	5000	2700	350	1800	15000
6	111	4 x 24	198	108	14	72	33000
6.0	3150	4 x 22	6000	2900	350	2000	18000
8	123	4 x 30	235	114	14	78	40000
7.5	3150	4 x 30	6300	2900	350	2000	19000
10	126	4 x 40	247	114	14	78	41800
9.5	3350	4 x 37	6500	3100	300	2100	21000
12	132	4 x 50	256	123	12	84	46000



Why a Stephens?

- Owned by Stephens family since 1957
- Reputation of honest, reliable and second to none sales and service
- In-house CNC/Machine shop
- Certified in-house scales to keep load cell size and quantity down
- Simple and easy to service and maintain, features standard off the shelf parts
- Each plant is designed for your seismic requirements

Proud
Members of



Stephens
www.stephensmfg.com



Find us on:



Stephens

CONCRETE PLANTS • Tompkinsville, KY

Stephens Manufacturing

P.O. BOX 488 • TOMPKINSVILLE, KY 42167

PHONE: 800-626-0200 • OUTSIDE the USA 270-487-6774

FAX: 270-487-8368

www.stephensmfg.com



Local Distributor: